

# Official 3x3 Basketball Equipment & Software

## Appendix to the 3x3 Official Rules

<b>1. INTRODUCTION</b>	<b>2</b>
<b>2. COMPETITION MANAGEMENT SOFTWARE</b>	<b>2</b>
<b>3. BACKSTOP UNIT</b>	<b>2</b>
<b>3.1. BACKBOARD</b>	<b>3</b>
<b>3.2. BASKET RING</b>	<b>5</b>
<b>3.3. BASKET NET</b>	<b>7</b>
<b>3.4. BACKBOARD SUPPORT STRUCTURE</b>	<b>7</b>
<b>3.5. PADDING</b>	<b>7</b>
<b>4. SHOT-CLOCK</b>	<b>9</b>
<b>5. BASKETBALLS</b>	<b>10</b>
<b>6. GAME CLOCK &amp; SCOREBOARD</b>	<b>11</b>
<b>7. COMPUTER HARDWARE AND SOFTWARE</b>	<b>12</b>
<b>8. PLAYING FLOOR</b>	<b>13</b>
<b>9. PLAYING COURT</b>	<b>14</b>
<b>10. LIGHTING</b>	<b>15</b>
<b>11. WHISTLE</b>	<b>165</b>
<b>12. ADVERTISING BOARD</b>	<b>16</b>
<b>13. REFERENCES</b>	<b>167</b>

## 1. Introduction

The 3x3 Basketball Equipment section of the Official 3x3 Basketball Rules specifies all basketball equipment required at a 3x3 game.

This Appendix shall be used by all parties involved directly in the game as well as by basketball equipment manufacturers, local organisers and FIBA, and to establish national and international standards.

3x3 can be played both indoor and outdoor. Therefore, the weather- and water-resistant requirements (such as stainless steel or water-proof) of the equipment mentioned in this document refers only for competitions played outdoors.

The approval of equipment is divided into 2 levels:

### **Level 1: Suitable for elite level competition, including FIBA 3x3 Official Competitions and direct qualifiers thereto,**

FIBA 3x3 Official Competitions' are defined in Chapter 1 – Book 6 of the FIBA Internal Regulations. All equipment at these competitions must be FIBA Approved Level 1.

### **Level 2: Suitable for any other 3x3 or outdoor basketball not included in Level 1,**

FIBA approved equipment is strongly recommended at all levels of play, and Level 1 equipment is preferred.

Note: This Appendix focuses on the requirements and specifications and does not describe testing procedures. For procedures and measurement tolerances refer to the "Handbook of Test Methods and Requirements for 3x3 and Outdoor Basketball Equipment" which can be acquired from the FIBA Equipment & Venue Centre ([equipmentandvenue@fiba.basketball](mailto:equipmentandvenue@fiba.basketball)).

## 2. Competition management software

Any 3x3 game shall be managed with 3x3 Event Maker ([www.em.fiba3x3.com](http://www.em.fiba3x3.com)) and results; FIBA recommends the use of scores.fiba3x3.com during the event for operational efficiency and benefit of live stats. Furthermore, additional ranking points are provided at individual player basis in case score.fiba3x3.com has been used.

## 3. Backstop unit

There shall be 1 backstop unit (Diagram 1) placed at the end of the playing court and consisting of the following parts:

- 1 backboard
- 1 basket ring with a mounting plate
- 1 basket net
- 1 backboard support structure
- Padding
- For Level 1, a shot-clock integrated in the padding

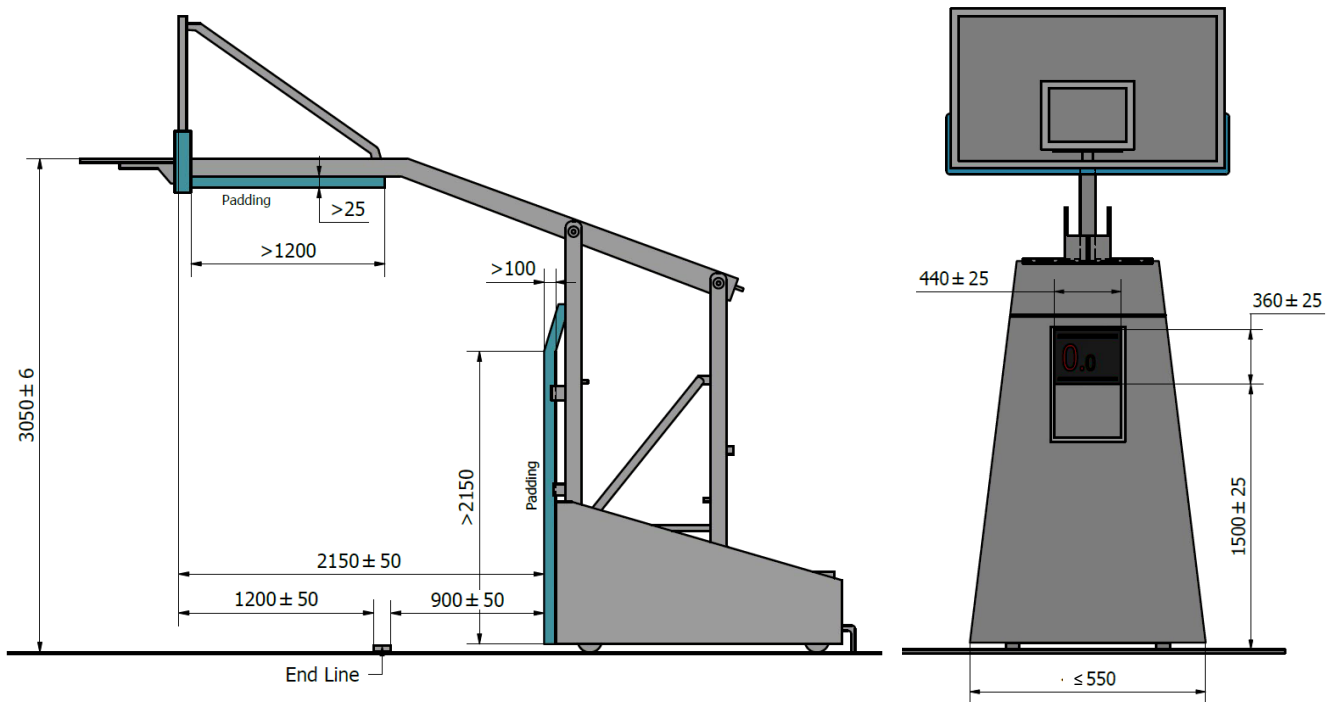

Diagram 1 – Backstop Unit

For outdoor units, attention must be made during the design and fabrication of the backstop unit that corrosion resistance is treated with the utmost importance and should ensure the longevity of the unit when installed outdoors. This is particularly important when specifying the materials, fasteners and coatings of components integral to the structural soundness of the unit.

### 3.1 Backboard

3.1.1. For Level 1 the backboards shall be made of non-reflective laminated safety glass or tempered glass, with a thickness of between 11.8 mm and 13.5 mm, with a flat front surface and shall:

- Have a protective framework of the backboard support structure around the outer edge
- Be manufactured such that, if broken, the pieces of glass do not split off or cause any risk of injury.

3.1.2. For Level 2, the backboards may be any of the following:

- Laminated/tempered glass (identical to Level 1)
- Transparent acrylic or polycarbonate
- Fiberglass, steel or aluminium, painted white.

3.1.3. For outdoor competition, the backboard must be of waterproof/weatherproof materials, including line painting.

3.1.4. The backboards shall measure 1,800mm (+ a maximum of 30mm) horizontally and 1,050 mm (+ a maximum of 20mm) vertically.

3.1.5. All lines on the backboards shall be:

- In white, if the backboards are transparent.
- In black, if the backboards are painted white (Level 2 only)
- 50 mm in width

3.1.6. The borders of the backboards shall be marked with a boundary line (Diagram 2) and an additional rectangle behind the ring as follows:

- Outside dimension: 590 mm (+ a maximum of 200mm) horizontally and 450 mm (+ a maximum of 8 mm) vertically.
- The top edge of the base of the rectangle shall be level with the top of the ring and 150 mm (-2 mm) above the bottom edge of the backboard.

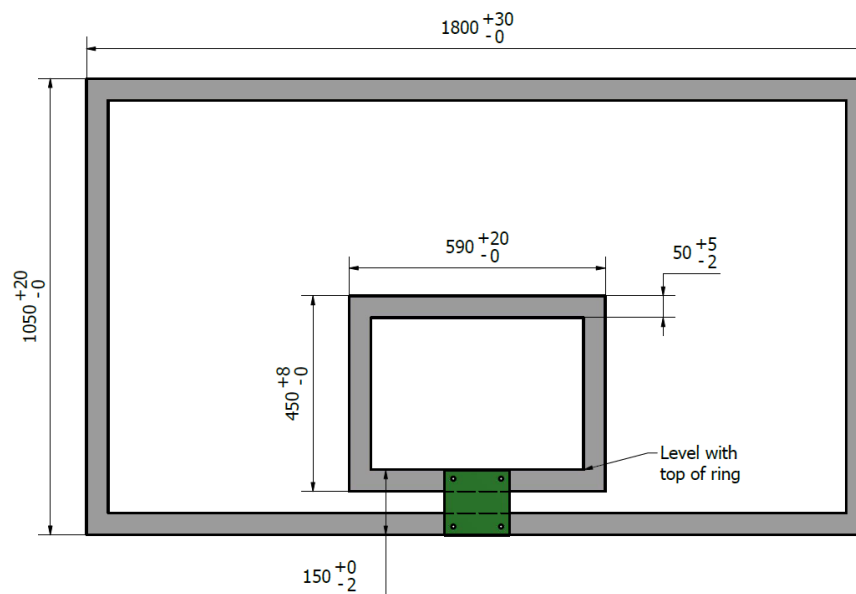

Diagram 2 – Backboard markings

3.1.7. The backboard shall be firmly mounted on the backboard support structures at right angles to the floor, parallel to the baseline. The central vertical line on the front surface, extended down to the floor, shall touch the point on the floor which lies 1,200 mm from the centre point of the inner edge of the baseline, on an imaginary line drawn at right angles to the baseline.

3.1.8. When a basketball is dropped onto the backboard, from 1.8 m, it shall rebound from it with a minimum rebounding height of 50 %.

## 3.2 Basket Ring

3.2.1. The ring shall be made of solid stainless steel and shall:

- Have an inside diameter of a minimum of 450 mm and a maximum of 459 mm.
- Be painted orange within the following Natural Colour System (NCS) or RAL Classic spectrums:

NCS:

S0580-Y70R (CMYK: 0, 63, 79, 4)

S0585-Y70R (CMYK: 0, 70, 92, 5)

S1080-Y70R (CMYK: 0, 65, 85, 13)

RAL:

RAL 2004 (CMYK: 0, 65, 87, 0)

RAL 2008 (CMYK: 0, 70, 90, 0)

RAL 2010 (CMYK: 0, 78, 100, 0)

- Have its metal a minimum of 16 mm and a maximum of 20 mm in diameter.

3.2.2. The net shall be attached to each ring in 12 places. The fittings for the attachment shall:

- Not have any sharp edges or gaps,
- Have gaps smaller than 8 mm, to prevent fingers from entering,
- Not be designed as hooks for Level 1.

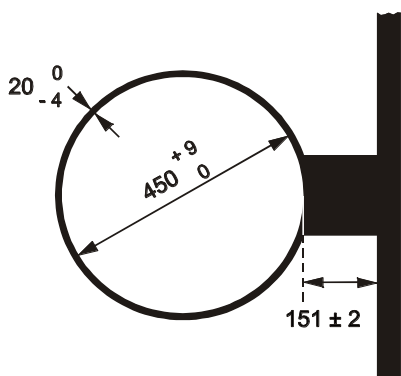

Diagram 3 Basket Ring dimensions

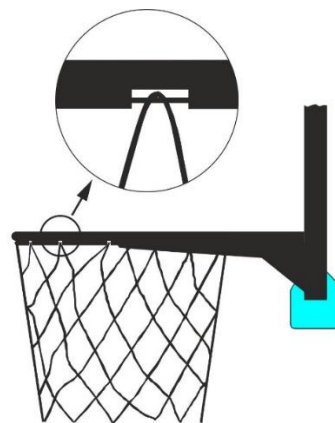

Diagram 4 Attachment of net (example)

3.3.1. The ring shall be fixed to the backboard support structures in such a way that any force applied to the ring cannot be transferred to the backboard itself. Therefore, there shall be no direct contact between the ring mounting plate and the backboard (Diagram 5).

3.3.2. The top edge of the ring shall be positioned horizontally, 3,050 mm ( $\pm$  a maximum of 6 mm) above the floor, equidistant from the two (2) vertical edges of the backboard.

3.3.3. The point on the inside circumference of the ring nearest the backboard shall be 151 mm ( $\pm$  a maximum of 2 mm) from the face of the backboard.

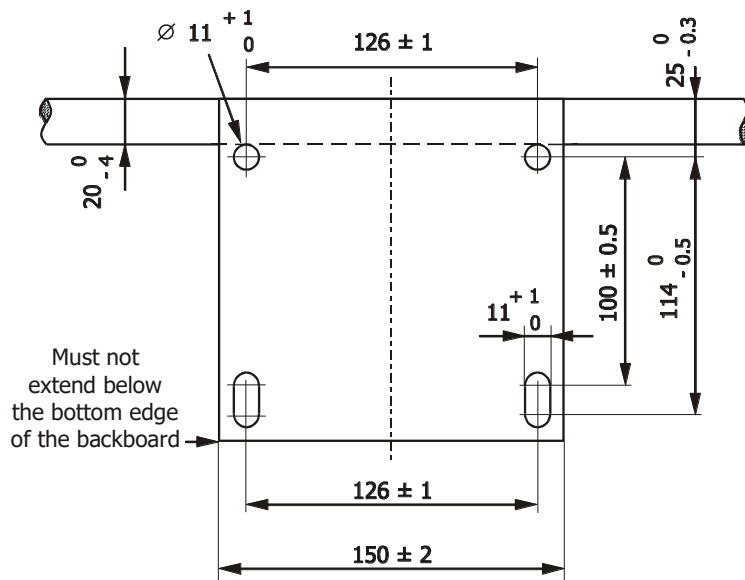

Diagram 5 – Ring mounting plate (example dimensions)

3.3.4. For existing basket support structures, it is recommended that the ring mountain plate be fixed to the framework according to the measurements given in Diagram 6.

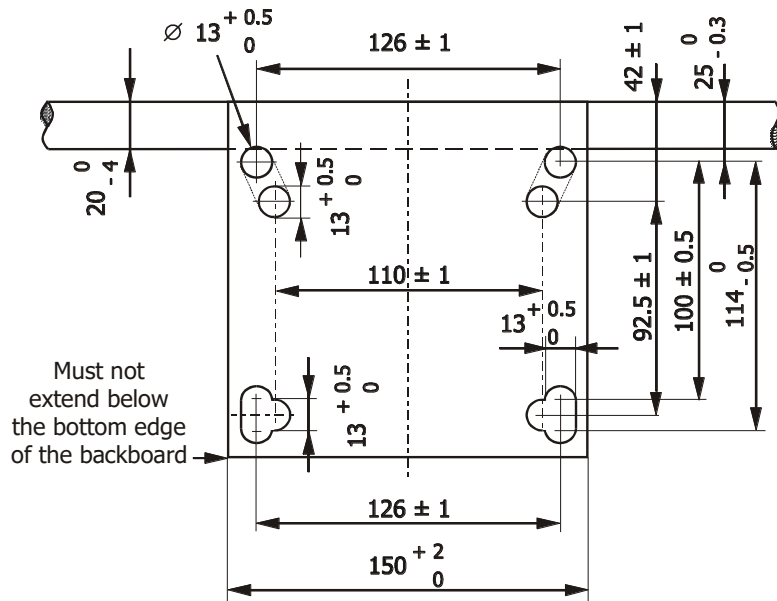

Diagram 6 – Ring mounting plate for existing baskets (example dimensions)

3.3.5. Pressure release rings with the following specifications are required:

- The pressure release mechanism shall not cause any damage to either the ring or the backboard. The design of the ring and its construction shall be such that the players' safety is ensured.
- The pressure release ring shall have a "positive-lock" mechanism which must not disengage until a static load of a minimum of 82 kg and a maximum of 105 kg has been applied vertically to the top of the ring at the most distant point from the

backboard. The pressure release ring mechanism shall be adjustable within the given static load range.

- When the pressure release mechanism is released, the front or the side of the ring shall rotate no more than 30 degrees and no less than 10 degrees below the original horizontal position.
- After release and with the load no longer applied the ring shall return automatically and instantly to its original position. No fissures and no permanent deformation of the ring shall be observed.
- The rebound/elasticity of the ring and support system shall be within 35% - 50% energy absorption range of the total impact energy.

### **3.4. Basket net**

3.4.1. The net shall be made of white cord and shall be:

- Suspended from the ring.
- Manufactured so that they check the ball momentarily as it passes through the basket.
- No less than 400 mm and no more than 450 mm in length.
- Manufactured with 12 loops to attach it to the ring.

3.4.2. The upper section of the net shall be semi-rigid to prevent:

- The net from rebounding up through or over the ring, creating possible entanglement.
- The ball from becoming trapped in the net or rebounding back out of the net.

### **3.5. Backboard support structure**

3.5.1. Only mobile or floor-fixed backboard support structures shall be used for competition.

3.5.2. The backboard support structure shall be:

- Distance of at least 900 mm, measured from the upright front surface (including padding) to the baseline (Diagram 1).
- A maximum of 1550 mm in width (Diagram 1).
- Adjusted such as that once the top edge of the ring is at a height of 3,050 mm from the playing floor, this height cannot be changed.

3.5.3. Shall fulfil the requirements for Structure Rigidity and Stability in accordance with EN 1270.

3.5.4. For Level 1, the vibration of the backboard support unit in which the displacement exceeds 5 mm, shall last less than 4 seconds after a dunk shot.

### **3.6. Padding**

3.6.1. The backboard and backboard support structure must be padded.

3.6.2. For Level 1, the padding shall be of a solid black colour.

3.6.3. The padding shall be 20 to 27 mm thick from the front, back and side surface of the backboard. The padding shall be 48 to 55 mm thick from the bottom edge of the backboard.

3.6.4. The padding shall cover the bottom surface of the backboard and the side surface to a distance of 350 to 450 mm from the bottom. The front and back surface must be covered to a minimum distance of 20 to 25 mm from the bottom of the backboard.

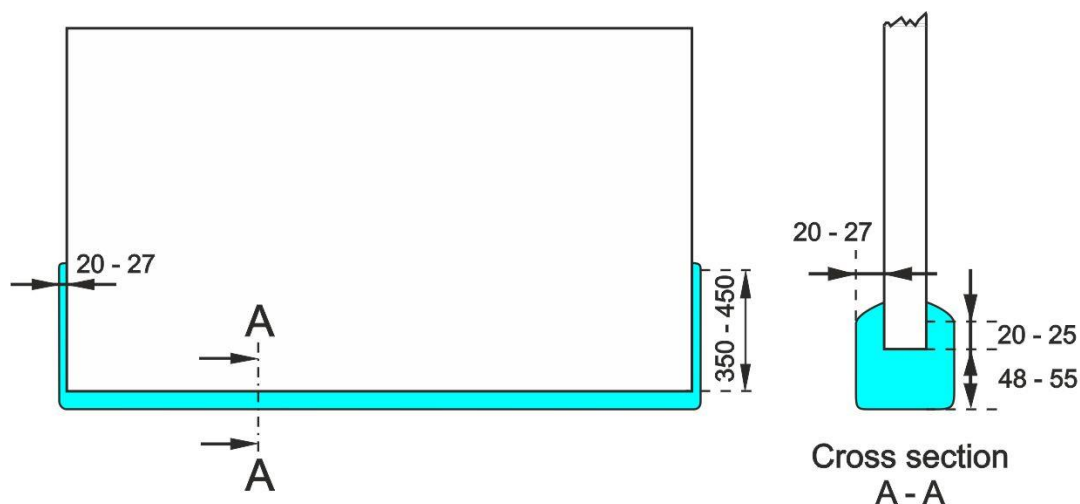

Diagram 7 – Backboard Padding

3.6.5. The padding of the backboard support structure shall cover:

- The vertical edges on each side, to a minimum height of 2,150 mm from the floor and with a minimum thickness of 100 mm (Diagram 1).
- The bottom and side surfaces of the supporting arm of the backboard, from the back surface of the backboard over a minimum length of 1,200 mm along the arm, with a minimum thickness of 25 mm (Diagram 1).

3.6.6. To protect players during impact all padding shall:

- Be constructed so as to prevent limbs from being trapped.
- Have a maximum indentation factor of 50 %. This means that when a force is applied suddenly to the padding, the indentation in the padding does not exceed 50 % of its original thickness.
- Have a peak deceleration value of 500 m/s<sup>2</sup> or less.



#### 4. Shot Clock

There must be 1 shot clock unit:

- integrated into the backstop unit, or
- placed next to the back stop (Level 2 only)

4.1. The shot clock shall have:

- A separate control unit provided for the shot clock operator, with a very loud automatic signal to indicate the end of the shot clock period when the display shows zero (0).
- A display unit with a digital countdown, indicating the time in seconds only.

4.2. The shot clock shall have the ability to be:

- Started from 12 seconds.
- Stopped with the display indicating the time remaining.
- Restarted from the time at which it was stopped.
- Manually set to any number between 1 and 12.
- Showing no display, if necessary.
- Started, stopped and restarted from 99 seconds for side-competitions.

4.3. The shot clock shall:

- For Level 1, be mounted in the padding on the backboard support structure with an elevation of 1500mm above the floor level (Diagram 1) and have a display height of 360 mm  $\pm$  25 mm and a display width of 440 mm  $\pm$  25 mm.
- Have the numbers of the shot clock in red colour and a minimum digit height of 200mm and minimum digit width of 100mm.
- Be able to withstand direct impacts from basketballs, according to the Shot Clock Durability Test.
- Have electromagnetic compatibility in accordance with the statutory requirements of the respective country.

In addition, shot clocks intended for outdoor use and the associated electrical equipment shall be suitably designed to prevent the ingress of water or particulate.



Diagram 8 – Shot Clock example

## 5. Basketballs

- 5.1. Only FIBA 3x3 approved ball shall be used for all categories.
- 5.2. Only FIBA 3x3 official ball shall be used in FIBA 3x3 Official Competitions (as defined in Book 6 of FIBA's Internal Regulations).
- 5.3. For Level 1, the outer surface of the ball shall be made of composite or synthetic leather.
- 5.4. For Level 2, in addition to composite or synthetic leather, the outer surface of the ball may be made of rubber.
- 5.5. The surface of the ball shall be free of toxic materials and materials which may cause an allergic reaction, including AZO-dyes, soluble heavy metals, Phthalate and PAH. It is the responsibility of the ball manufacturer to test their balls according to applicable national legislation.
- 5.6. The basketball surface shall provide a proper grip over the entire ball.
- 5.7. The ball shall:
- Be spherical, with a maximum of 12 seams not exceeding 6.35 mm in width.
  - Consist of two principal contrasting colours.
  - Be inflated to an air pressure such that, when it is dropped onto the playing floor from a height of approximately 1,800 mm measured from the underside of the ball, it will rebound to a height of between 960 mm and 1,160 mm, measured to the underside of the ball.
  - Be marked with the recommended inflation pressure or pressure range.
  - Be within the circumference and weight tolerances outlined in Table 1.

Table 1 – Basketball circumference and weight tolerances

<b>Ball</b>	<b>3x3 (Level 1 and 2)</b>
<b>Circumference</b>	720 - 740 mm
<b>Weight</b>	580 - 620 g

- 5.8. Any 3x3 basketball carrying a valid FIBA certification must also display the associated FIBA-Licence serial number and the FIBA 3x3 Approved logo, other than the FIBA 3x3 Official Basketball (Diagram 9) that can use the FIBA 3x3 logo.



Diagram 9 – FIBA 3x3 Official Basketball

5.9. The FIBA 3x3 Official Basketball inflation pressure shall be set between 7.5 and 8 psi.

5.10. In addition to checking the specifications listed above, the ball shall meet the requirements of the following:

- Durability test
- Loss of pressure test
- Inflation stress test (Level 1 only)
- Heat storage test (Level 1 only)

## 6. Game clock & Scoreboard

6.1. The main game clock shall:

- Be a digital countdown clock with an automatic signal sounding for the end of the game as soon as the display shows zero (00:00.0).
- Have the ability to indicate time remaining in minutes and seconds; as well as tenths (1/10) of a second only during the last minute of the game.
- Be placed so that it is clearly visible to everyone involved in the game, including the spectators.

6.2. An LED monitor screen, minimum 32" shall be used, which will be connected to the [scores.fiba3x3.com](https://scores.fiba3x3.com).

6.3. The scoreboard will show:

- The digital countdown game clock.
- The points scored by each team
- The team's names.
- The number of team fouls
- Foul bonus situation
- Optionally, events logo or hashtag; as well as sponsors' logo

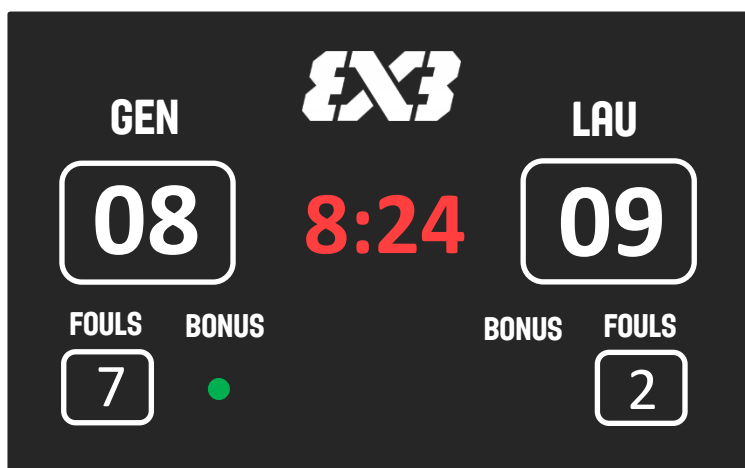

Diagram 10 – FIBA 3x3 Scoreboard Display

In addition, the scoreboard shall;

- Not have any sharp edges or burrs.
- Be mounted securely.
- Have specific protection, if necessary, which shall not impair the readability of the scoreboard.

## 7. Computer hardware and software

If real-time scoring and statistics are provided from the venue, the following technical infrastructure must be followed:

- Internet connection must be available and reliable.
- The scoring and statistics computer must have enough of processing power and memory.
- Recommended browsers such as Chrome must be used with the latest version
- Computer must be freed from any other software that may slow down the speed of processing and the scoring or statistics computers are not to be used for other purposes at the same time.

More specific details are provided in the Digital Tools section of [help.fiba3x3.com](http://help.fiba3x3.com)

- <http://help.fiba3x3.com/en/support/solutions/articles/35000012970-what-kind-of-computer-do-i-need-for-running-scores-fiba3x3-com->
- <http://help.fiba3x3.com/en/support/solutions/articles/35000012969-do-i-need-an-internet-connection-to-use-scores-fiba3x3-com->
- <http://help.fiba3x3.com/en/support/solutions/articles/35000012971-which-browser-should-i-use-for-scores-fiba3x3-com->

## 8. Playing floor

8.1. The playing surface shall be:

- FIBA Approved Wooden or Synthetic Flooring when playing indoors
- FIBA Approved 3x3 Flooring for outdoors when playing outdoors.

8.2. The court shall be 15x11 meters (playing surface) + additional boundary of 2m baseline, 1,5m (exceptionally minimum of 1m) short side and 1m for the long side opposite the backstop

8.3. The playing floor shall be marked with 50mm white lines (in any case, clearly visible)

8.4. The playing field shall be coloured in 2 colours: key and 2-point area in one colour, the remaining playing area in another colour. The colours recommended by FIBA are as in Diagram 11.

8.5. The Flooring must adhere to the following sports functional requirements (Table 2):

Table 2 – Sports Functional Requirements for Outdoor 3x3 Flooring

Performance Property	Outdoor 3x3 Flooring Requirements		
<b>Force reduction,</b> according to EN 14808	Point Elastic:	Level 1: 25% - 75%	Uniformity (absolute) ±5% from average
		Level 2: 11% - 75%	Uniformity (absolute) ±7% from average
	Mixed Elastic: 45% - 75%		Uniformity (± 5 % from average)
	Area Elastic: 40% - 75%		
	Combined Elastic: 45% - 75%		
<b>Vertical deformation,</b> according to EN 14809	Point Elastic: ≤ 3.5mm		Uniformity (± 0.7 mm from average)
	Mixed Elastic: ≤ 3.5mm		
	Area Elastic: 1.5mm – 5.0mm		
	Combined Elastic: 1.5mm – 5.0mm		
<b>Ball rebound,</b> according to EN 12235	Level 1: ≥90%		Uniformity (± 3 % from average)
	Level 2: ≥85%		
<b>Slip resistance,</b> according to EN 13036	Dry		Average: ≥ 80 ≤ 110
	Wet*		Average: ≥55 ≤110
<b>Resistance to wear,</b> according to EN 5470	≤ 1,000 mg (or, ≤ 4,000 mg for polymeric outdoor surfaces)		
<b>Rolling load,</b> according to EN 1569 (for permanent installations)	Permanent indentation of ≤ 0.5 mm		
<b>Assembly/Disassembly Wear</b> (for portable systems)	No visual wear		
<b>Dimensional Stability</b> according to EN 13746	≤1%		
<b>Water Permeability</b> according to EN 12616	≥150 mm/h**		

\* Systems which fail to meet this requirement are suitable in dry conditions only.



## 10. Lighting

- 10.1. The vertical illuminance (EC) (illuminance towards the main camera) and (EV) (illuminance towards the mobile cameras) are a key parameter for the picture quality. If there are varying levels of vertical illuminance at different positions on the playing court then it can be disturbing when panning the camera. It is therefore essential that there is total uniformity in the distribution of the vertical illuminance over the entire playing court (also called uniformity of the vertical illuminance).
- 10.2. The vertical illuminance shall be kept as constant as possible in the four main directions facing the sides of the playing court where the cameras are generally located.
- 10.3. The venue lighting must be designed for television broadcasting.
- 10.4. The playing court shall be uniformly and adequately lit. The lighting shall be of minimum 1.200 lux in playing area.

## 11. Whistle

- 11.1 The referee's whistle shall meet the decibel and frequency requirements outlined in Table 3.
- 11.2 The whistle shall:
- Be able to withstand repeated use at a high pressure (durability test).
  - Be able to withstand repeated dropping (damage test).

All readings shall be taken at 3 m from the front of the whistle.

Table 3 – Whistle volume and frequency requirements

Competition	Decibel at 8.3 kPa			Frequency range at 8.3 kPa		
	Initial test	Post durability test	Post damage test	Initial test	Post durability test	Post damage test
Level 1	≥ 105	≥105 & ± 10 % of pre-result		≥ 170	≥170 Hz & ± 10 % of pre-result	
Level 2	≥ 95	≥95 & ± 10 % of pre-result		≥ 150	≥150 Hz & ± 10 % of pre-result	

- 11.3 Whistles shall be constructed of materials that do not cause a direct harm to the user. As such, the whistle shall conform to the requirements of the following, unless the local standards allow for deviations:
- EN 71 -3+A1:2014 Safety of toys – Part 3 migration of certain elements aluminium, antimony, arsenic, barium, cadmium, chromium(iii), chromium (vi), cobalt, copper, lead, manganese, mercury, nickel, selenium, strontium, tin and zinc.
  - PAH Testing in line with REACH Recommendations Annex XVII - Benzo[a]pyrene (BaP), Benzo[e]pyrene (BeP), Benzo[a]anthracene (BaA), Chrysen (CHR), Benzo[b]fluoranthene (BbFA), Benzo[k]fluoranthene (BkFA) & Dibenzo[a,h]anthracene (DBAha).
  - Phthalates Testing in line with REACH Recommendations Annex XVII - Di-2-ethylhexyl phthalates (DEHP, Diisononyl phthalate (DINP), Dibutyl phthalate

(DBP), Di-n-octyl phthalate (DNOP, Benzylbutyl phthalate (BBP), and Diisodecyl phthalate (DIDP)

## **12. Advertising board**

This only applies in case advertising boards are used.

- 12.1. Have no burrs and all edges shall be rounded off.
- 12.2. Be in accordance with the national safety requirements for electrical equipment in the respective country.
- 12.3. Be non-flammable.



### 13. References

- [1] Handbook of Test Methods and Requirements for 3x3 and Outdoor Basketball Equipment, FIBA Equipment and Venue Centre.
- [2] National Colour System of Standardiseringkommissionen i Sverige (SIS), Doc. No. SS019102.
- [3] RAL Colour Standard
- [4] EN 1270: Playing field equipment – Basketball equipment – Functional and safety requirements, test methods.
- [5] EN 14808: Surfaces for sports areas – Determination of shock absorption.
- [6] EN 14809: Surfaces for sports areas – Determination of vertical deformation.
- [7] EN 12235: Surfaces for sports areas – Determination of vertical ball behaviour.
- [8] EN 13036-4: Road and airfield surface characteristics – Test methods – Part 4: Method for measurement of slip/skid resistance of a surface – The pendulum test.
- [9] EN 5470-1: Rubber- or plastic-coated fabrics – Determination of abrasion resistance – Part 1: Taber abrader.
- [10] EN 1569: Surfaces for sports areas – Determination of the behaviour under a rolling load.
- [11] EN 13746: Surfaces for sports areas – Determination of dimensional changes due to the effect of varied water, frost and heat conditions.
- [12] EN 12616: Surfaces for sports areas – Determination of water infiltration rate.
- [13] EN 71-3+A1: Safety of toys – Part 3: Migration of certain elements aluminium, antimony, arsenic, barium, cadmium, chromium(iii), chromium (vi), cobalt, copper, lead, manganese, mercury, nickel, selenium, strontium, tin, and zinc.
- [14] REACH Recommendations: PAH Testing in line with REACH Recommendations Annex XVII – Benzo[a]pyrene (BaP), Benzo[e]pyrene (BeP), Benzo[a]anthracene (BaA), Chrysen (CHR), Benzo[b]fluoranthene (BbFA), Benzo[k]fluoranthene (BkFA) & Dibenzo[a,h]anthra-cene (DBAha).
- [15] REACH Recommendations: Phthalates Testing in line with REACH Recommendations Annex XVII – Di-2-ethylhexyl phthalates (DEHP, Diisononyl phthalate (DINP), Dibutyl phthalate (DBP), Di-n-octyl phthalate (DNOP), Benzylbutyl phthalate (BBP), and Diisodecyl phthalate (DIDP).